

R 1006LC

Designation : swivel fitting, cylindrical head, Installation from the outside possible



Patent No : 9806556

Sealing strip between glazing available p.8.26

REFERENCE TO ORDER			
GLASS THICKNESS	Ø AXIS	LENGTH AXIS (mm)	ARTICLE CODE
8 ≤ V ≤ 14	M12	50	R1006LC-01
14 < V ≤ 18	M12	50	R1006LC-02
SPECIAL	SPECIAL	SPECIAL	R1006LC-SP

Dimensions

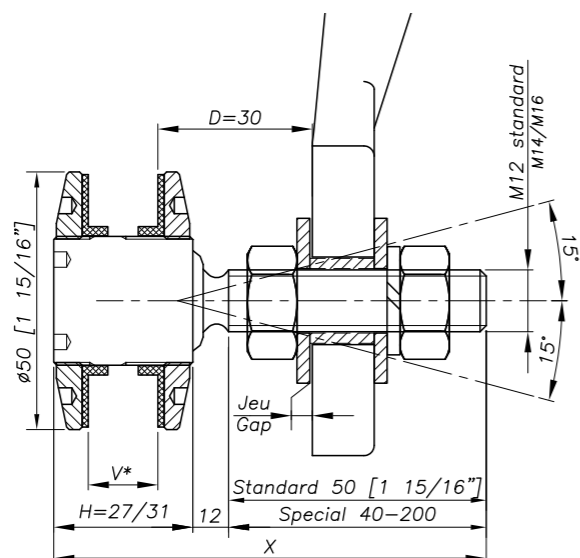

H = Swivel body corresponding to the thickness of the glass.
V* = glass thickness

Glass drilling

MONOLITHIC GLASS

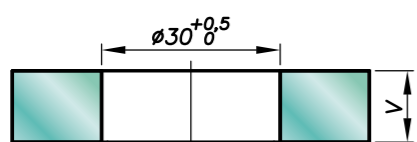

LAMINATED GLASS

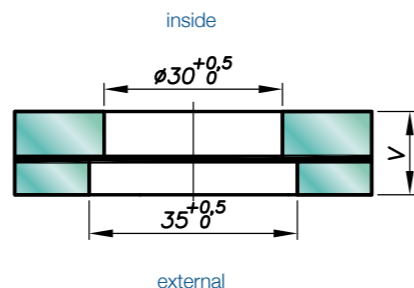

Available for glass thicknesses from 8 to 31.52 mm, for other thicknesses please consult us.

It is important to provide the following information with each request: the glass composition (ex.: 10 mm monolithic, 8.8.4 laminated, 8.8.2-12-10 insulating) / the length and diameter of the threaded axle if not standard dimensions (M14, 65 mm) / the reference of the spider to be used as support, or the thickness of an existing support for the delivery of the spacer.

R 1006LC

Mechanical performance

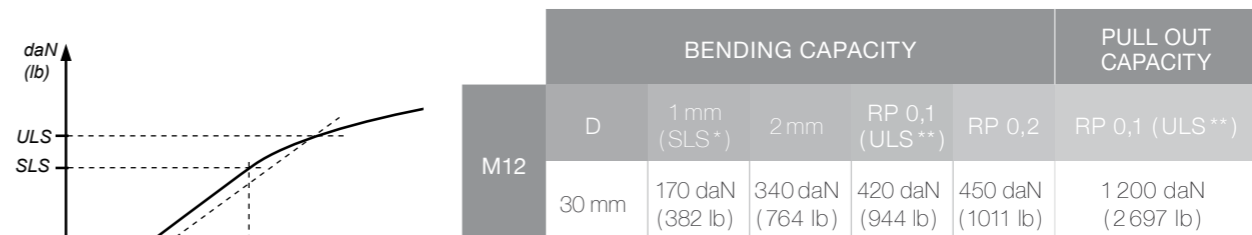

*SLS : Serviceability limit state : Bending capacity à 1 mm
**ULS : Ultimate limit state : Load at the elastic limit Rp0,1
Values are given without factor of safety
Tests available online : www.sadev.com

Components

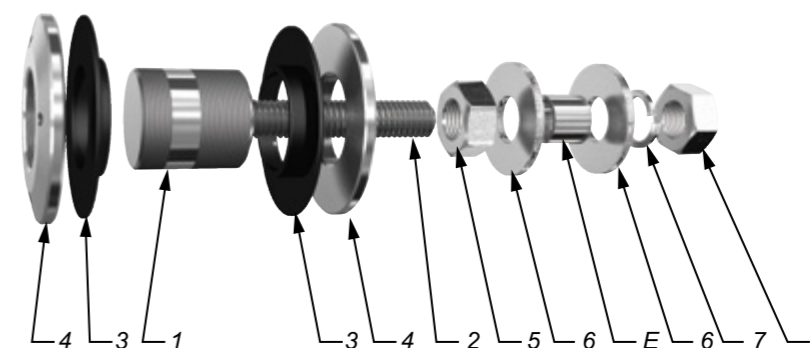

MARK	QUANTITY	DESIGNATION	MATERIAL
1	1	Swivel body	X2 Cr Ni Mo 17.12.2 as per EN 10088-3
2	1	Threaded Axle	X4 Cr Ni Mo 16.5.1 as per EN 10088-3
3	2	Glass hole grommet	Polyacétal noir / polyéthylène noir
4	2	Glass nut Ø50	X2 Cr Ni Mo 17.12.2 as per EN 10088-3
5	2	Nut DIN 934	A4
6	2	Washer	A4
7	1	Lock washer DIN127	A4

Suggested mounting instruction

A – Classic mounting

Insert parts N° 1, 2, 4 and 3 into the glass hole. Place the second contact washer N°3 over assembly N°2 and thread on glass nut N°4. Tighten to 20Nm for tempered glass using SADEV catalog ref. 758-11-60. Thread on nut N°5 and apply washer N°6. Insert the threaded axle into the support with spacer E (available on request), see technical page. Adjust the depth. Mount the second washer N°6, lock washer N°7, and nut N°5. Tighten to 60Nm (45 ft-lb) using a 19 mm wrench.

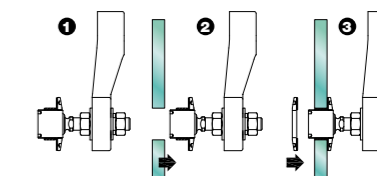

B – Blind mounting : installation from the outside (no access to the structure)

Mount nut N°5 and washer N°6 onto assembly N°1,2. Insert the threaded axle into the support with spacer E (available on request), see technical page. Adjust the depth. Mount the second washer N°6, lock washer N°7, and nut N°5. Tighten to 60Nm (45 ft-lb) using a 19mm wrench. Mount the glazing. Mount contact washer N°3 + plate N°4 and tighten to 20Nm for monolithic glass and 10Nm for laminated glass using SADEV catalog ref. 758-11-60.

SADEV recommends using thread locking, except specific mounting constraint.